

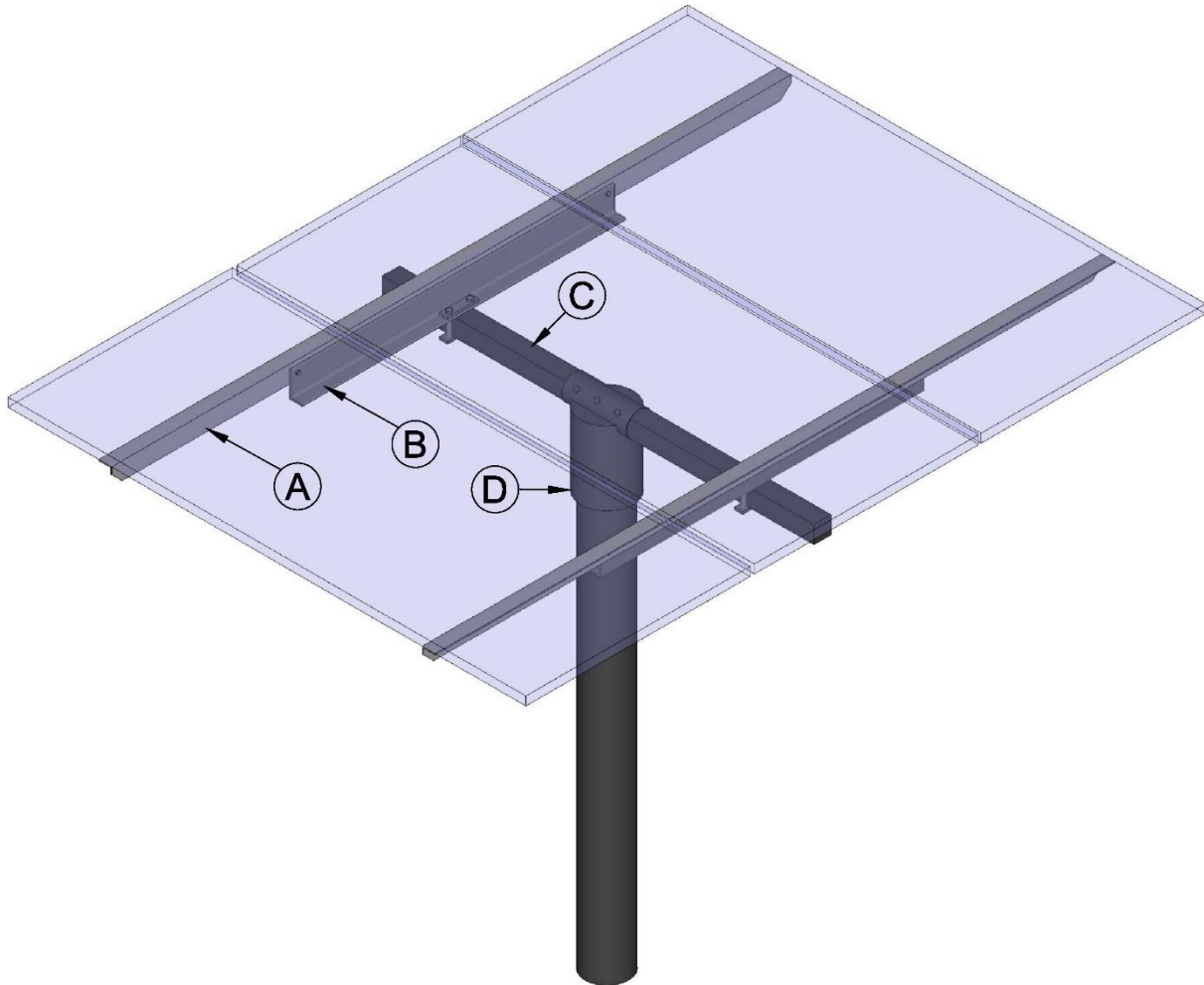

## Top of Pole Mount Assembly Instructions



### **UPM 4X**

Standard stock tee socket sized for 4" schedule 40 or 80 pipe

- A. **ALUMINUM RAILS:** 3" X 1-1/2" X 3/16" UNIVERSAL ALUMINUM T-SLOT EXTRUSSION OR PUNCHED ALUMINUM ANGLE WITH CHAMFERED ENDS
- B. **CROSS PIECES:** 3" X 2" ALUMINUM ANGLE
- C. **CENTER TUBE:** 2" X 2" SQ. TUBE WITH 3" ROUND TUBE BUSHING
- D. **TEE SOCKET:** STEEL TEE SOCKET WITH SET BOLTS FOR ADJUSTMENT

**Note:** Number of panels may vary, length of rail may vary.  
Rev. 12/17



## COMPONENTS FOR THIS MOUNT

### Box #1

- (1) Tee Socket
- (2) Hardware Bags

#### Bag #1

- 4 – 3/8" x 1" bolts
- 8 – 3/8" SS flat washers
- 4 – 3/8" nyloc nuts
- (all for attaching Crosspieces to Rails)

2 – set bolts for tightening Tee Socket to Post

4 – 1/2" x 4" bolts

4 – 1/2" nyloc nuts

(use with 4 aluminum flat bars that are in bag #2 for attaching Crosspieces to Center tube)

#### Bag #2

4 – aluminum flat bars

SS bolts and flange nuts for mounting Panels to Rails

Instructions

### Box #2

- (1) Center tube
- (2) Cross Pieces
- (2) Rails

## ASSEMBLY INSTRUCTIONS

- Put Tee Socket on top of 4" schedule 40 or 80 post.
- Slide Center tube into top of Tee Socket with one of the flat square tube surfaces horizontal (level).
- Tighten down on the 3 set bolts on Tee Socket. Make sure center tube faces east/west, then tighten 2 square head set bolts on Tee Socket.
- Loosely attach Crosspieces with the angle pointing towards the tee socket on Center tube using flat bars and bolts (1/2"x 4" bolts and 1/2" nyloc nuts) provided. One flat bar goes on top of the crosspiece and one goes below the Center tube.
- Attach aluminum panel Rails to Crosspieces with all other hardware from bag #1. See rail configuration (page 4 of these instructions) for detail.
- Lay first module on top of Rails and adjust distance between Rails to fit mounting holes on modules in a landscape orientation.
- Attach modules to Rails by sliding mounting bolts in T-slot. Start at one end of the Rails and add modules out from there, leaving approx. 1/4" space between modules. Make sure bolts are finger tight only.
- When all modules are attached and LOOSELY bolted, square up assembly by measuring diagonally from corner to corner of array and **then tighten all the mounting bolts and the rest of the assembly hardware.**

**RECOMMENDATIONS FOR DIMENSIONS OF POST HOLE FOR STANDARD INSTALLATION OF  
GENERAL SPECIALTIES MANUFACTURING UPM4X**

<b>Depth of Hole</b>	<b>Width of Square Hole / Cubic Yards of concrete needed</b>	<b>Diameter of Round Hole / Cubic Yards of concrete needed</b>
50"	18" / .34 CY	23" / .44 CY

Your building department may require the foundation for a PV array post mount to be designed by a structural engineer licensed in the state where the PV array is to be erected. This is required because failure of a post mount foundation may be a threat to the safety of people and property in its proximity. At a minimum, failure will result in costly damage to the PV modules. The foundation described here is suitable for most soil types, but no warranty of its suitability for your particular soil or wind conditions is offered or implied.

If you are unable to dig holes of these dimensions because you encounter bed rock or if you have very loamy or loose sandy soil, (get the recommendation of a soil engineer or building department), then you may have to seek a design for an alternative foundation construction.

For type and size of pole to install in concrete foundation, refer to chart below.

**RECOMMENDATIONS FOR POLE HEIGHT FOR  
GENERAL SPECIALTIES MANUFACTURING UPM4X**

We cannot guarantee a standard 1.67 safety factor if these recommendations are not observed. Since we cannot assess each customer's individual site and conditions, a professional installer and the local building department should be consulted for the safest and most effective installation.

<b>UPM Model</b>	<b>Post Size (sch = schedule, or thickness of pipe wall)</b>	<b>Max Pole Height above concrete Base w/array @ 45° tilt</b>	<b>Clearance between top of concrete and lowest point on array @ 45° tilt</b>	<b>Max Pole Height above concrete base w/array @ 60° tilt</b>	<b>Clearance between top of concrete and lowest point on array @ 60° tilt</b>	<b>Max Pole Height above concrete base w/array @ 90° tilt</b>	<b>Clearance between top of concrete and lowest point on array @ 90° tilt</b>
<b>UPM4X</b> Standard stock tee socket 4"	4" sch 40 4 1/2" OD	7' 6"	4' 8"	6'	2' 6"	5' 3"	1' 1"
	4" sch 80 4 1/2" OD	10'	7' 2"	8'	4' 6"	6' 9"	2' 7"

## RAIL CONFIGURATION

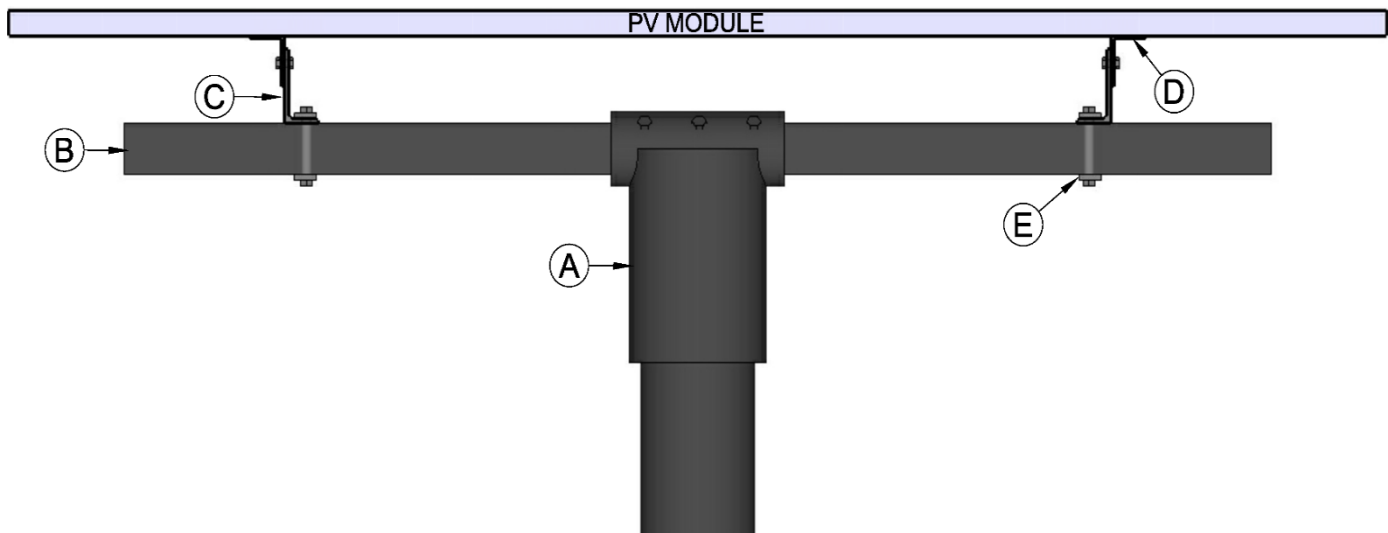

- A. BLACK POWDER COATED TEE
- B. SQUARE GALVANIZED CENTER TUBE WITH ROUND TUBE BUSHING
- C. ALUMINUM ANGLE CROSS PIECE
- D. UNIVERSAL ALUMINUM T-SLOT EXTRUCTION RAILS
- E. ALUMINUM FLAT BAR WITH 2 HOLES

**Note:** Rails may go toe in or toe out depending on panel mounting hole location. Number of panels may vary.

## INSTRUCTIONS FOR ATTACHING SOLAR PANEL TO MOUNTING RAILS

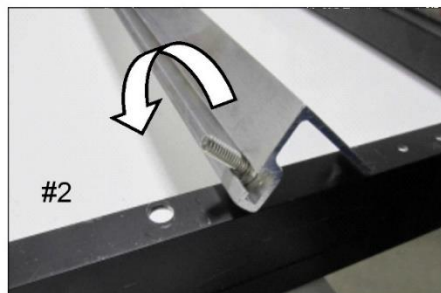

Lay T-Slot rails across the short axis of the panel as shown in Photo #1. Slide stainless bolts into T-slot of rail and position so they are opposite to the mounting holes on the frame of the panel as shown in Photo #2.

Then roll the rails over so the bolts slip into the holes on the panel frame. Place the flange nut on your finger with the flange UP and thread onto the bolt from underneath as shown in Photo #3. Finger tighten.